

MEGADUCT

Copper Busduct Trunking System

P1 Series



MEGADUCT



CONTENT

Introduction Product Overview

- Technical Features
- Conductor
- Epoxy
- Other Insulation Type
- Joint System
- Tap-Off Unit
- IP Busduct

Electrical Characteristics

Standard Component

Busduct Layout Design Consideration

Measurement Guideline

Illustrations Of Megaduct Busduct Trunking System

Installation

Quality Control

Certificates

Standard & Testing

Project References

- Site Photo
- Project Photo

Continuous Busduct Monitoring System

MEGADUCT



OUR BACKGROUND

LINKK Busway Systems (M) Sdn Bhd is the leading designer and manufacturer of busduct trunking systems in Asia Pacific. Established in 1992, we have expanded our operations and now supply busduct trunking systems to over 30 countries worldwide.

Our focus on product R&D and manufacturing standards ensures that we are able to continuously improve product design and performance. In providing a product line that complies with newest international standards, we are constantly upgrading ourselves with renowned certification bodies like ASTA, KEMA, UL etc.

LINKK is determined to combine the best available product with the most comprehensive customer service in our delivery commitment to all our clients. Together with a strong track record of both private and national-level projects, this is the best testament to our reliability.

OUR VISION

- We aim to become the leading busduct manufacturer in the world.
- To meet customer needs and provide prompt services.
- Committed to produce uniform product quality and achieve total customer satisfaction.

VISION STATEMENT

We aim to design and manufacture the most reliable busduct system and provide custom engineering to our clients.

COMPANY QUALITY POLICY

- Total customer's satisfaction.
- Consistent product quality.
- Continual improvement.

OUR MISSION

- Improving our quality by benchmarking our product and process.
- Expanding our range of products and services.
- Increasing our marketing activities worldwide.
- Investing in R&D.
- Developing and enhancing our human resources.

MEGADUCT

TECHNICAL FEATURES

MEGADUCT is a busduct system developed by **LINKK Busway Systems (M) Sdn Bhd**. It is designed for commercial and industrial electrical distributions.

Standards

MEGADUCT systems are tested and certified by **KEMA, ASTA** and **UL** to comply with:

- IEC 61439 Part 1:2011 (Updated from IEC 60439 Part 1:2005)
- IEC 61439 Part 6:2012 (Updated from IEC 60439 Part 2:2005)
- IEC 60331
- IEC 60529

Busduct types

MEGADUCT is light weight, low impedance, non-ventilated, naturally cooled and totally enclosed within the **steel** or **aluminium** housing for protection against mechanical damages and dust accumulation. It consists copper bars with conductivity 100% (IACS).

- Verification of temperature rise at ambient 50°C.
- Feeder and plug-in type busducts.
- Indoor protection IP40~IP66.
- Outdoor protection IP66.
- Tap-off units(plug-in) protection IP2X/IP40/IP42/IP54/IP55.
- Fire retardant protection conforms to IEC 60331, CNS 14286 and BS 6387.

**IACS: International Annealed Copper Standard*



System

Our busduct can be applied to different system configuration as below:

- 3P3W
- 3P3W+50%E
- 3P4W
- 3P4W+50%E
- 3P4W+100%E
- 3P4W(200%N)
- 3P4W(200%N)+50%E
- 3P4W(50%N)
- 3P4W(50%N)+50%E

Other type of configuration can be designed upon special request from customer.

Unique features

The latest **MEGADUCT** systems are incorporated with many improved designs/features to provide cost effective solutions for building a power system:

- Higher efficiency in power transmission/distribution.
- Lower installation cost.
- Easier maintenance.
- More compact and suitable for tight plan room space.
- Higher reliability.
- Longer life span.
- Higher flexibility for future expansion.
- Extremely flexible in installation.

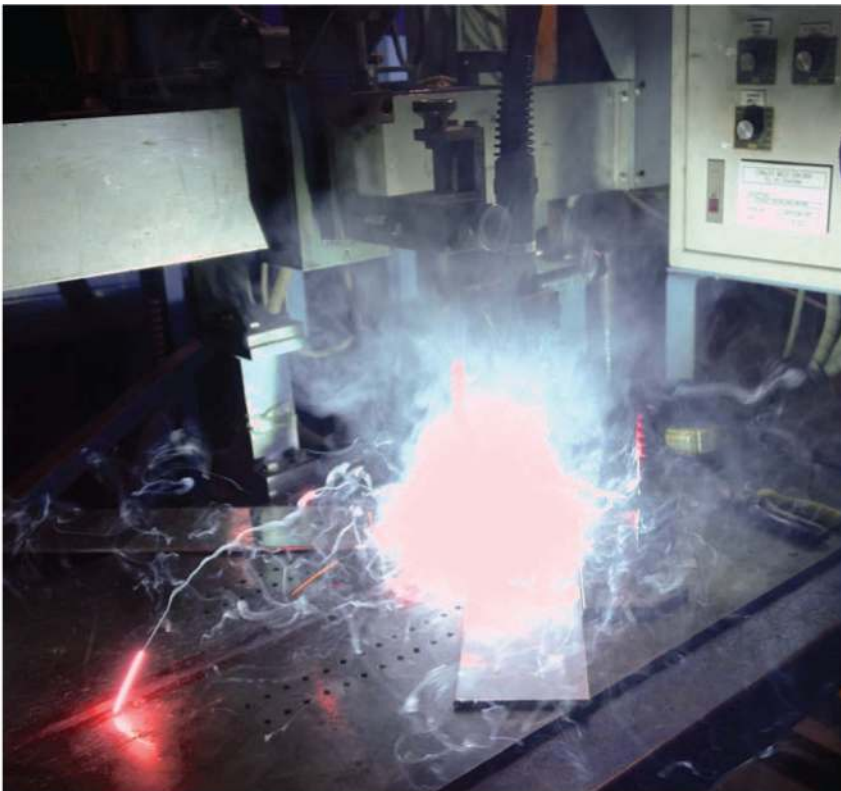

MEGADUCT

MEGADUCT CONDUCTOR

All MEGADUCT conductor are high density and conductivity. Copper conductor has minimum purity of 99.95% with conductivity of >100% IACS. It is fabricated through a sophisticated thermal compression process developed by Megaduct which involves application of tremendous heat under high pressure. It can be tinned or silver-plated with epoxy powder coated as insulation giving 100% water and chemical resistance.

Optional specifications can be designed and fabricated to customer requirement.

Advantage of using MEGADUCT conductor are:

- High electrical conductivity
- Low impurity
- Excellent fatigue resistance
- High thermal conductivity
- High mechanical strength
- Outstanding corrosion resistant

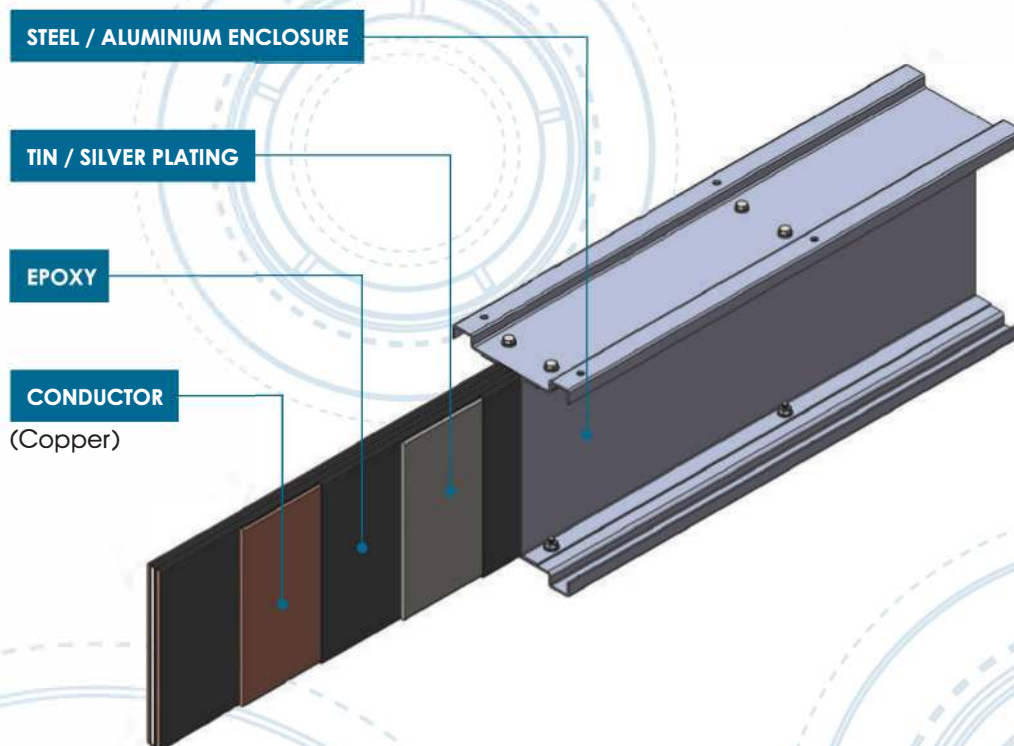

MEGADUCT EPOXY

Megaduct Epoxy System is the 3rd generation with own formulation. The class H-180°C standard epoxy coating provides 100% water proofing and high mechanical strength. It has been tested in accordance with IEC 61439-1 and IEC 61439-6.

Advantages of using epoxy coating as insulations are :

- Design to withstand glitch and spikes in electrical system.
- Design to cater for expansion and contraction during peak and off-peak hours.
- Capable of withstanding heat shock.
- High reliability under static conditions.
- High mechanical strength against impact.
- High thermal conductivity.
- Water and chemical resistant.

MEGADUCT

OTHER INSULATION TYPE

Besides epoxy insulation, we also provide other classes of insulation as below:

- **Class B** - It consists of two layers of Mylar(Polyester Film) which resists temperature up to 130°C.
- **Fire Rated** - It consists of 1 layer of Mylar(Polyester Film) and 2 layers of Mica (mineral silicate sheet) which resist temperature up to 950°C.

JOINT SYSTEM

In order to overcome extreme rugged conditions at site, the new MEGADUCT joint has been designed precisely and manufactured using the highest quality of materials to minimize all possible problems and enhance system performance. This special design provides outstanding features as follows:

- Incorporates a 5mm thermal expansion and movement at every joint.
- Allow $\pm 15\text{mm}$ of lateral adjustment(total 30mm) to correct site measurement inaccuracy.
- Able to tilt an angle of $\pm 5^\circ$ (total 10° along single axis).
- Bolt and nuts can be stainless steel, galvanized or chromed black high tensile steel.
- Degree of protection of IP40 ~IP66.
- Easy installation and removal of any joint in a run without disturbing the two adjacent busduct sections.
- Water/chemical resistance BMC insulation plates.

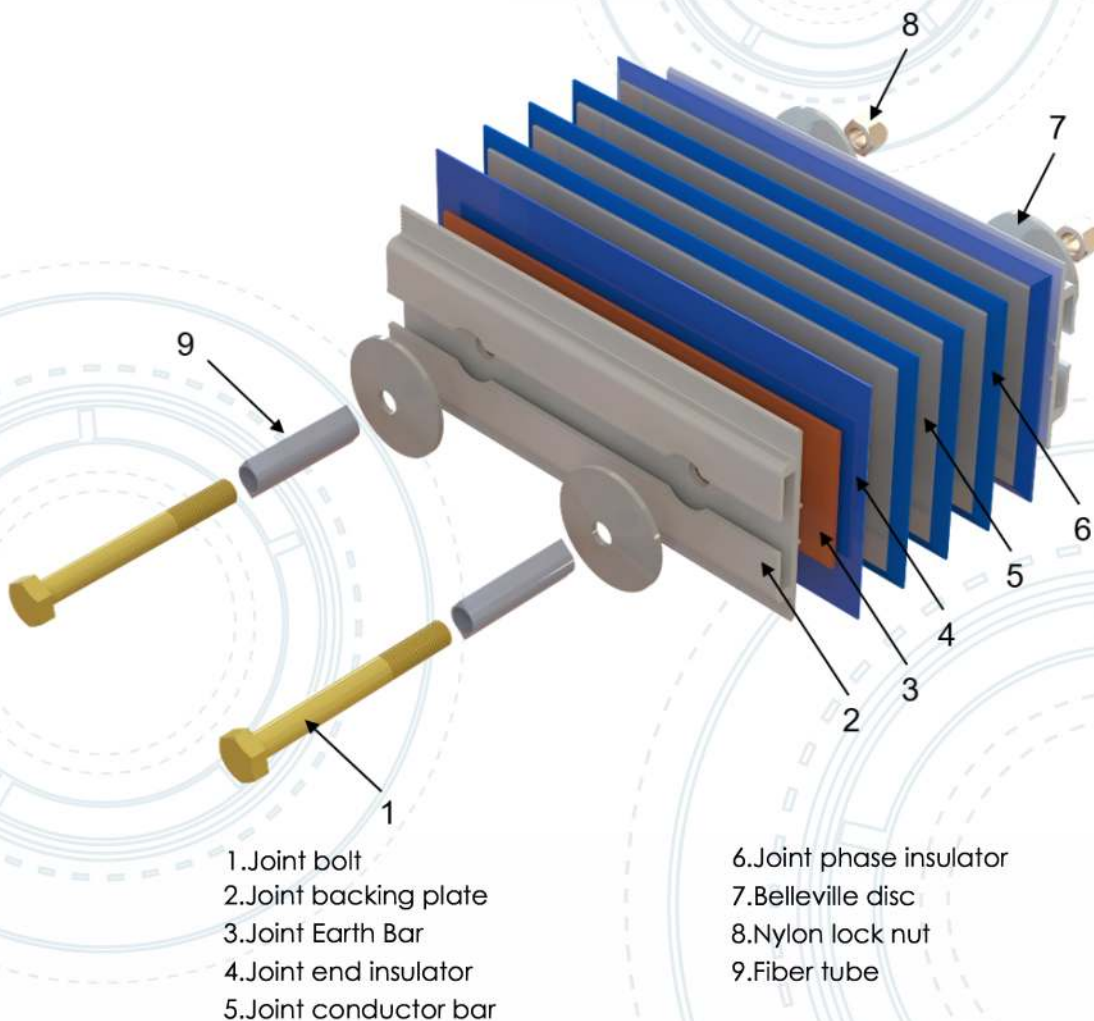

TAP-OFF UNITS(PLUG-IN UNITS)

Tap-off unit with moulded case circuit breaker (MCCB) or fused-switch breakers of various current ratings are available to cater for most installations. Maximum 5 tap-off units per side can be installed, total 10 nos per length of 3m busduct subject to the size of MCCBs.

- All tap-off unit are designed with interlocking safety features to prevent removal when tap-off unit in 'On' position.
- When tap-off unit cover is open, automatically MCCB cannot be turned 'On'

On/off handle design

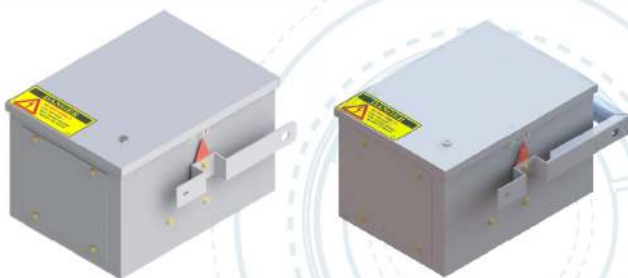

(a) Single Handle Design

(b) Double Handle Design

Bottom entry cable design

**For Tap Off-Unit above 300A is using double handle design.*



(a) Single Handle Design

(b) Double Handle Design

Top entry cable design

**For Tap Off-Unit above 300A is using double handle design.*

Rotary handle design



Bottom entry cable design

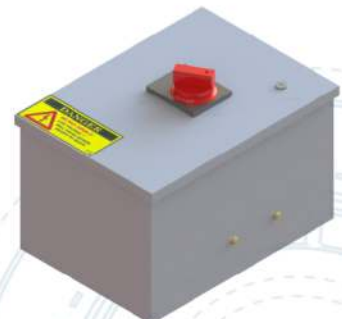

Top entry cable design

Outlet design



Bottom entry cable design

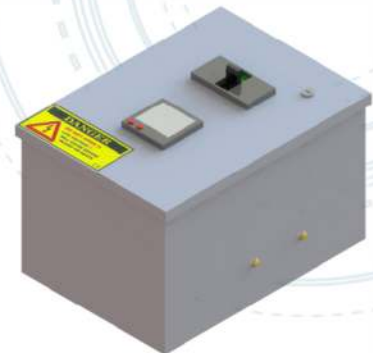

Top entry cable design

MEGADUCT

IP BUSDUCT

IP 54 to IP66 (Indoor Busduct Application)

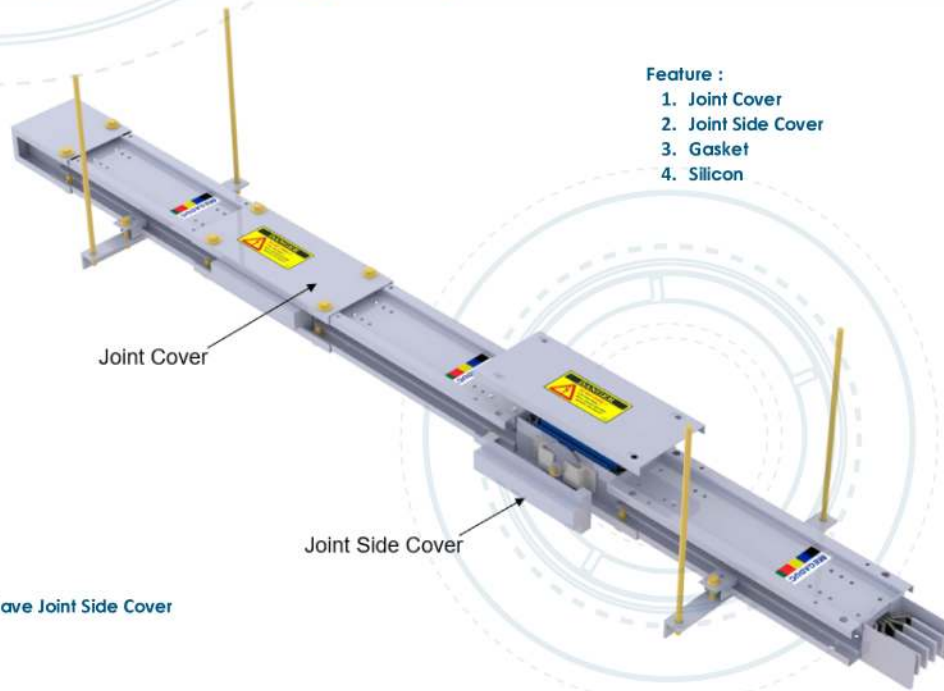

* IP42 does not have Joint Side Cover

IP 66 (Outdoor Busduct Application)

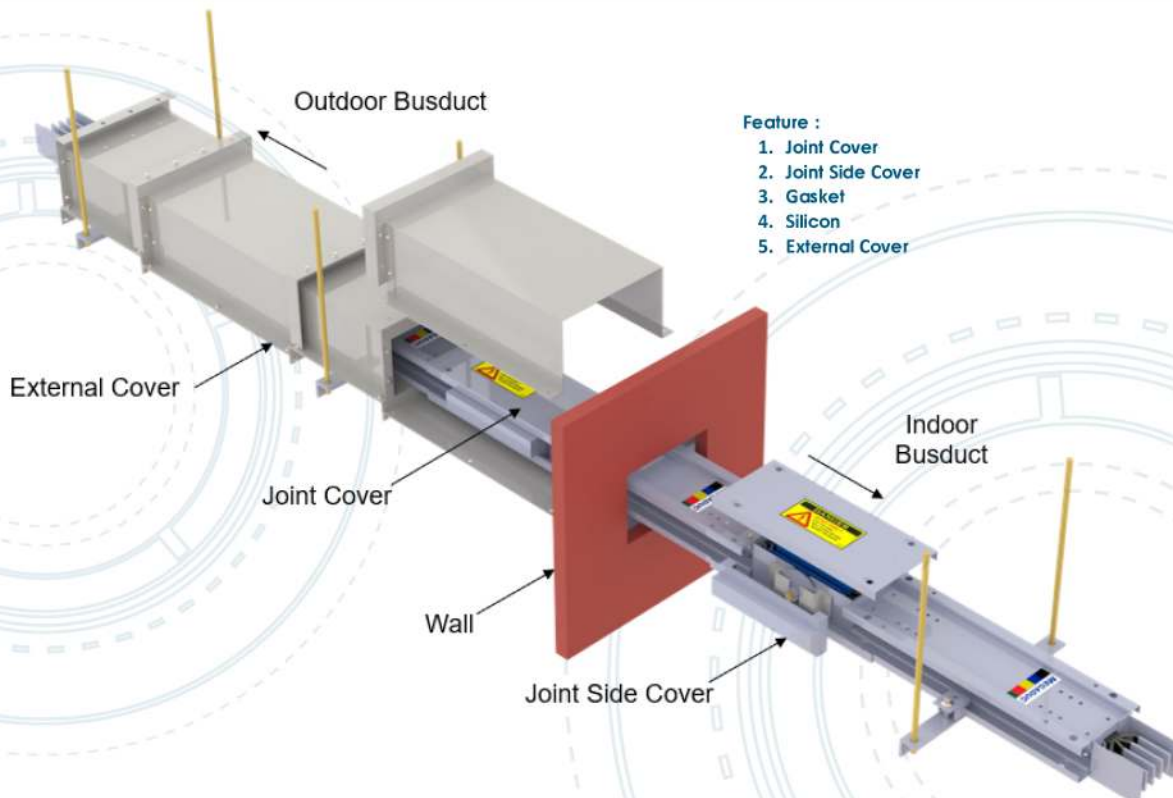

IP (INGRESS PROTECTION RATING GUIDE)

SOLIDS

1



Protection against a solid object greater than 50mm such as a hand.

2



Protection against a solid object greater than 12.5mm such as a finger.

3



Protection against a solid object greater than 2.5mm such as a screwdriver.

4



Protection against a solid object greater than 1mm such as a wire.

5



Dust Protected. Limited ingress of dust permitted. Will not interfere with operation of the equipment. Two to eight hours.

6



Dust tight. No ingress of dust. Two to eight hours.

Rating Example:

IP65

INGRESS PROTECTION

WATER

1



Protection against vertically falling drops of water. Limited ingress permitted.

2

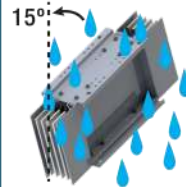

Protection against vertically falling drops of water with enclosure tilted up to 15 degrees from the vertical. Limited ingress permitted.

3

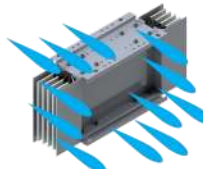

Protection against sprays of water up to 60 degrees from the vertical. Limited ingress permitted for three minutes.

4

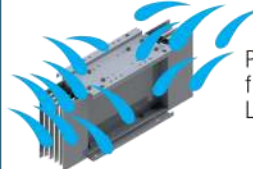

Protection against splashed from all directions. Limited ingress permitted.

5



Protection against jets of water. Limited ingress permitted.

6



Water from heavy seas or water projected in powerful jets shall not enter the enclosure in harmful quantities.

7

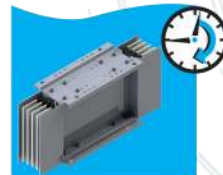

Protection against the effects of immersion in water between 15cm and 1m for 30 minutes

8

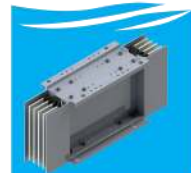

Protection against the effects of immersion in water under pressure for long periods.

CONFIGURATION OF MEGADUCT BUSWAY TRUNKING

Electrical Characteristics For Copper in 50Hz

Copper - 50Hz

Rated Current (A)	Impedance ($10^{-6} \Omega/m$)			Line to line voltage drop in (mV/m) at rated current and various power factors									
	R	X	Z	1.00	0.90	0.80	0.70	0.60	0.50	0.40	0.30	0.20	0.10
400	48.90	27.20	55.96	33.88	38.71	38.41	37.17	35.40	33.26	30.82	28.14	25.24	22.14
630	48.30	26.80	55.24	52.70	60.18	59.71	57.78	55.02	51.68	47.88	43.71	39.19	34.37
800	46.10	25.80	52.83	63.88	73.07	72.55	70.24	66.93	62.90	58.32	53.27	47.80	41.96
1000	44.72	21.40	49.58	77.46	85.87	84.21	80.69	76.13	70.83	64.95	58.60	51.81	44.63
1250	36.10	19.38	40.97	78.16	88.63	87.70	84.68	80.46	75.42	69.72	63.47	56.74	49.56
1600	30.80	15.35	34.41	85.36	95.36	93.81	90.13	85.24	79.52	73.13	66.19	58.75	50.86
2000	22.36	12.10	25.42	77.46	87.98	87.12	84.15	80.01	75.03	69.40	63.22	56.56	49.45
2500	17.89	10.30	20.64	77.47	89.16	88.73	86.08	82.16	77.36	71.86	65.79	59.19	52.12
3200	13.42	8.42	15.84	74.38	87.29	87.51	85.39	81.96	77.61	72.52	66.83	60.60	53.87
4000	9.58	4.67	10.66	66.37	73.84	72.51	69.57	65.71	61.21	56.20	50.78	44.98	38.83
5000	6.71	3.75	7.69	58.11	66.46	65.97	63.87	60.85	57.18	53.01	48.41	43.44	38.12
6000	6.60	2.91	7.21	68.59	74.91	73.02	69.61	65.35	60.48	55.15	49.43	43.35	36.95

Note: *For the 60Hz calculation, divide the reactance (X) by 0.83. And the resistance (R) remains unchanged due to the negligible difference in frequency.

*The voltage drop calculated at ambient Temperature of 50°C

Voltage Drop Calculation

As per IEC 61439-6:2012

$$DV = k \times (\sqrt{3}) \times I (R \cos\phi + X \sin\phi)$$

where,

DV	=	Line to line voltage drop per meter (to be calculated)
I	=	Load current
cos ϕ	=	Load Power Factor
sin ϕ	=	sin ϕ = Sq. Root (1 - Cos $^2\phi$)
R	=	Resistance
X	=	Reactance
k	=	The load distribution factor
*		1 if the load is concentrated at the end of the BT run;
*		(n+1) / (2 x n) if the load is uniformly spread between n branches
		(where n = no. of TOU)

MEGADUCT STANDARD COMPONENTS

Feeder Busduct

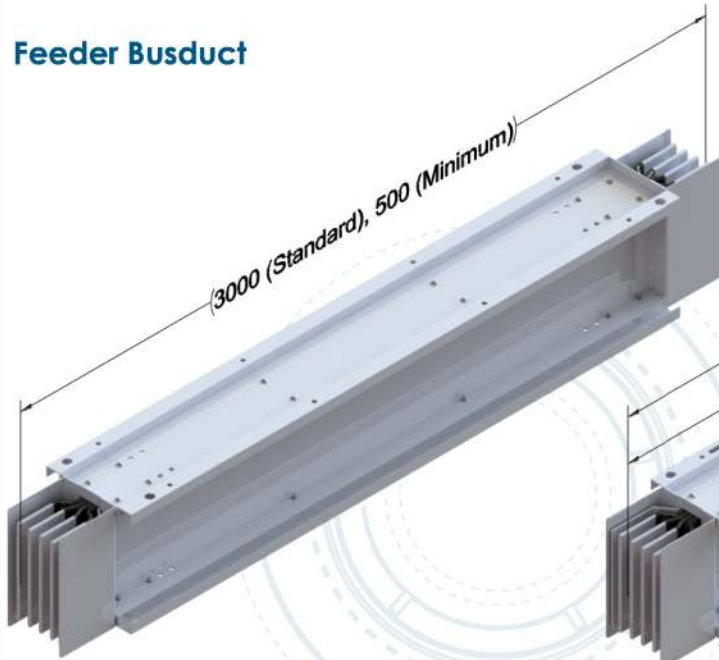

Plug-In Busduct

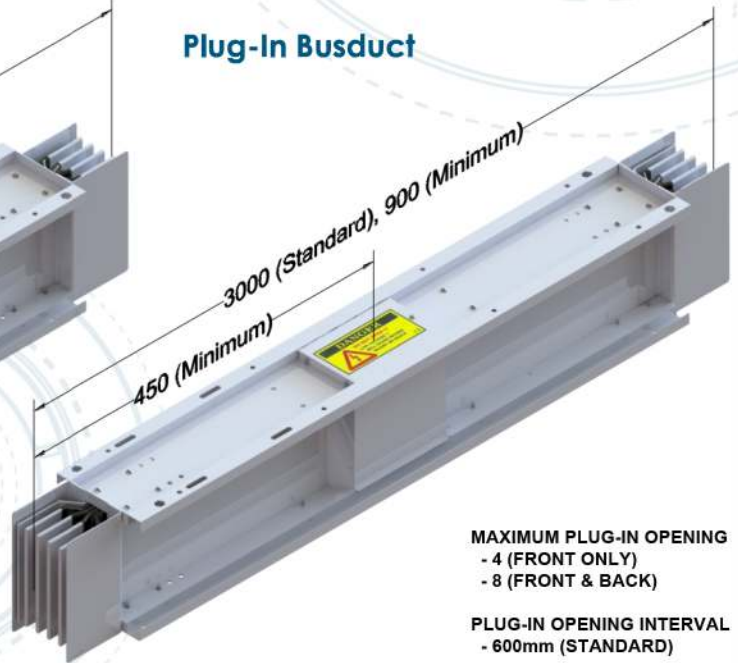

MAXIMUM PLUG-IN OPENING
 - 4 (FRONT ONLY)
 - 8 (FRONT & BACK)

PLUG-IN OPENING INTERVAL
 - 600mm (STANDARD)

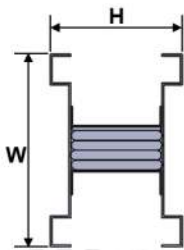

[Fig.L1-1]

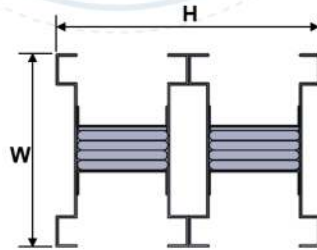

[Fig.L1-2]

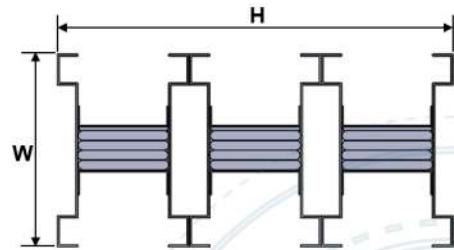

[Fig.L1-3]

Copper

Ampere (A)	W x H (mm)			Weight (kg/m)		Fig.
				3P4W	3P4W+50%E	
400	150	x	59	10.4	10.7	L1-1
630	150	x	69	12.5	13.0	L1-1
800	150	x	84	15.3	16.0	L1-1
1000	150	x	99	17.9	19.0	L1-1
1250	150	x	114	22.6	24.0	L1-1
1600	150	x	144	26.3	28.3	L1-1
2000	150	x	208	37.7	40.2	L1-2
2500	150	x	248	41.3	44.5	L1-2
3200	150	x	268	61.6	66.0	L1-2
4000	150	x	348	79.3	85.5	L1-2
5000	150	x	438	97.9	106.9	L1-2
6300	150	x	552	114.5	124.5	L1-3

MEGADUCT

Flange End

End Feed Cable Box

Mounting Cut Out

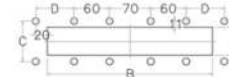
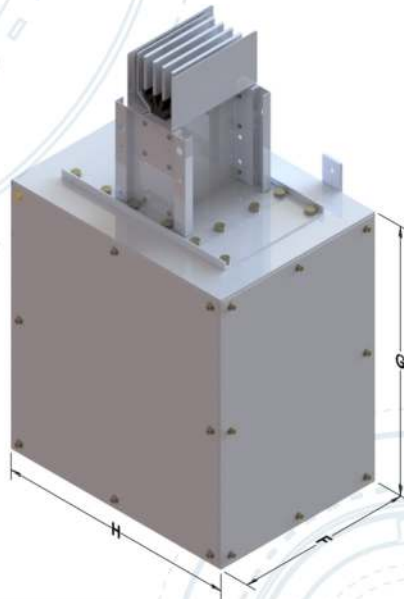
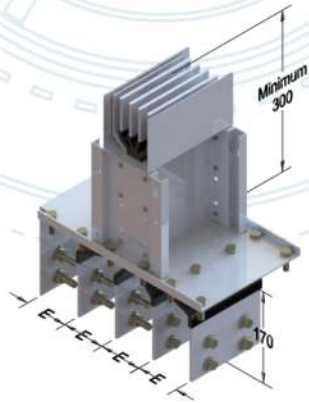

[Fig.2-1]

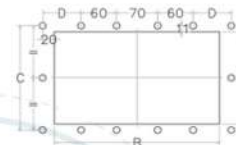

[Fig.2-2]

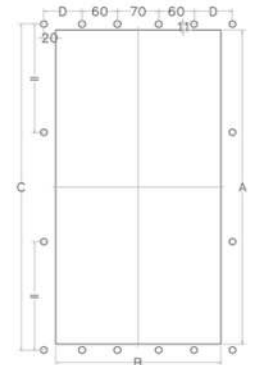

[Fig.2-3]

Copper

Ampere (A)	Mounting Cut Out (mm)				Interval (mm)	End Feed Box Size (mm)			Fig.
	A	B	C	D	E	F	G	H	
400	55	280	77	65	80	330	500	450	L2-1
630	65		87			330	500	450	
800	80		102			330	500	450	
1000	95		117			330	500	450	
1250	110		132			330	500	450	
1600	140	340	162	95	100	330	500	550	L2-2
2000	204		226			330	650	550	
2500	244		266			450	650	550	
3200	264		286			450	650	550	
4000	344		366			500	650	550	
5000	434		456			550	650	550	
6300	548	570	750	700	550	L2-3			

*Interval may varies to connection design, please refer to manufacturer.

Flatwise Elbow

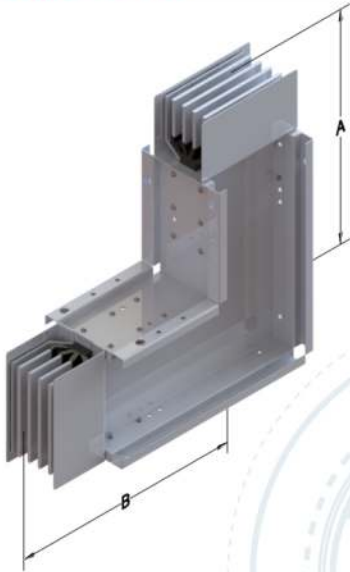

Ampere (A)	Copper		
	Standard (mm) A x B		
400	330	x	330
630	330	x	330
800	340	x	340
1000	345	x	345
1250	355	x	355
1600	370	x	370
2000	400	x	400
2500	420	x	420
3200	430	x	430
4000	470	x	470
5000	515	x	515
6300	575	x	575

Flatwise Offset

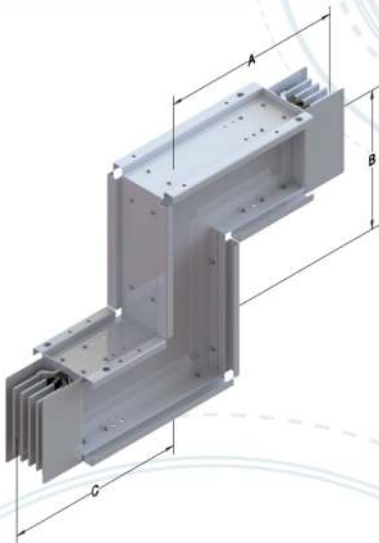

Ampere (A)	Copper				
	Standard (mm) A x B x C				
400	330	x	300	x	330
630	330	x	300	x	330
800	340	x	300	x	340
1000	345	x	300	x	345
1250	355	x	300	x	355
1600	370	x	300	x	370
2000	400	x	300	x	400
2500	420	x	300	x	420
3200	430	x	300	x	430
4000	470	x	300	x	470
5000	515	x	300	x	515
6300	575	x	300	x	575

Flatwise Tee

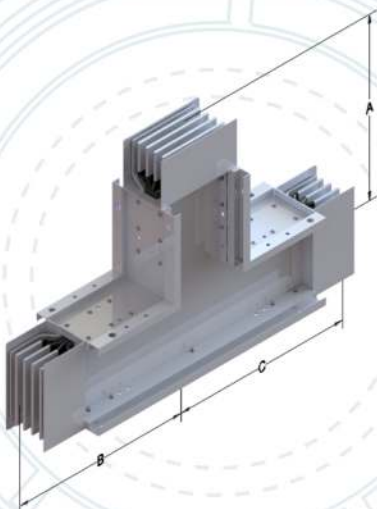

Ampere (A)	Copper				
	Standard (mm) A x B x C				
400	330	x	330	x	330
630	330	x	330	x	330
800	340	x	340	x	340
1000	345	x	345	x	345
1250	355	x	355	x	355
1600	370	x	370	x	370
2000	400	x	400	x	400
2500	420	x	420	x	420
3200	430	x	430	x	430
4000	470	x	470	x	470
5000	515	x	515	x	515
6300	575	x	575	x	575

MEGADUCT

Combination Elbow

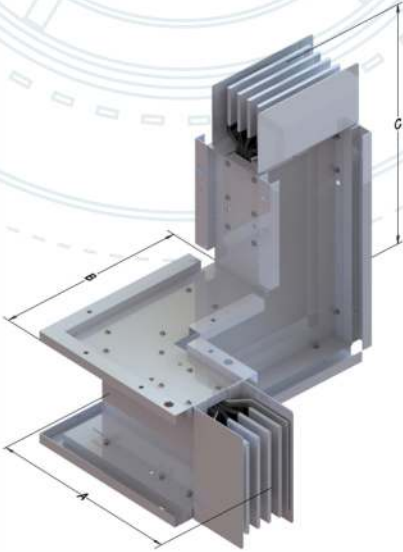

End Cover

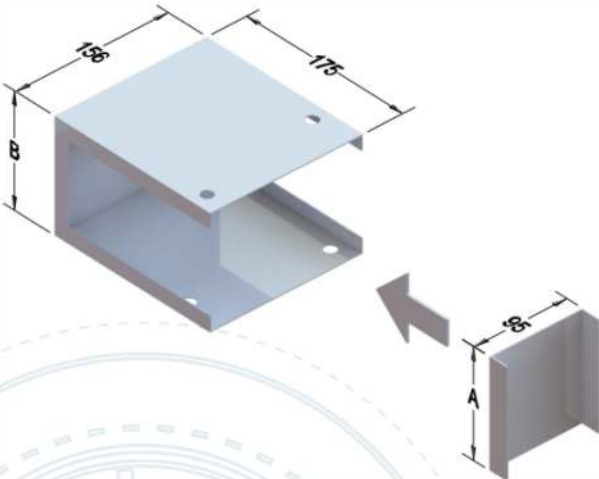

Wall Flange

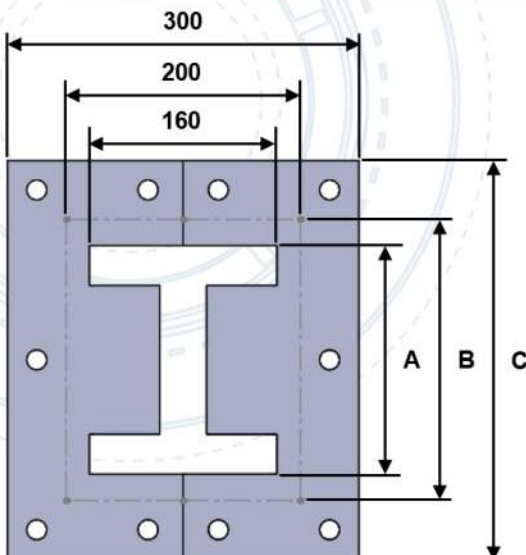

Ampere (A)	Copper				
	Standard (mm) A x B x C				
400	310	x	300	x	330
630	310	x	300	x	330
800	310	x	300	x	340
1000	310	x	300	x	345
1250	310	x	300	x	355
1600	310	x	300	x	370
2000	310	x	300	x	400
2500	310	x	300	x	420
3200	310	x	310	x	430
4000	310	x	340	x	470
5000	310	x	400	x	515
6300	310	x	460	x	575

Ampere (A)	Copper		
	Standard (mm) A x B		
400	59	x	65
630	69	x	75
800	84	x	90
1000	99	x	105
1250	114	x	120
1600	144	x	150
2000	208	x	215
2500	248	x	255
3200	268	x	275
4000	348	x	355
5000	438	x	445
6300	552	x	560

Ampere (A)	Copper				
	Standard (mm) A x B x C				
400	70	x	115	x	215
630	80	x	125	x	225
800	95	x	140	x	240
1000	110	x	155	x	255
1250	125	x	170	x	270
1600	155	x	200	x	300
2000	220	x	265	x	365
2500	260	x	305	x	405
3200	280	x	325	x	425
4000	360	x	405	x	505
5000	450	x	495	x	595
6300	565	x	610	x	710

Edgewise Elbow

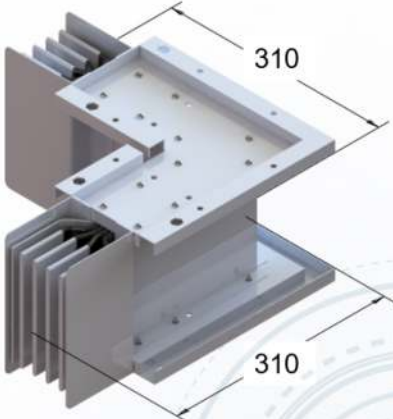

Edgewise Tee

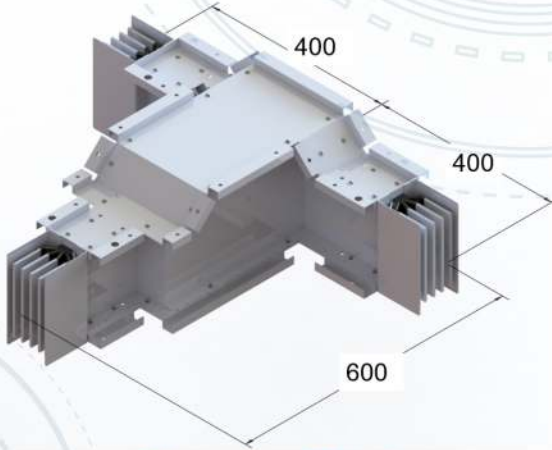

Phase Transposition Unit

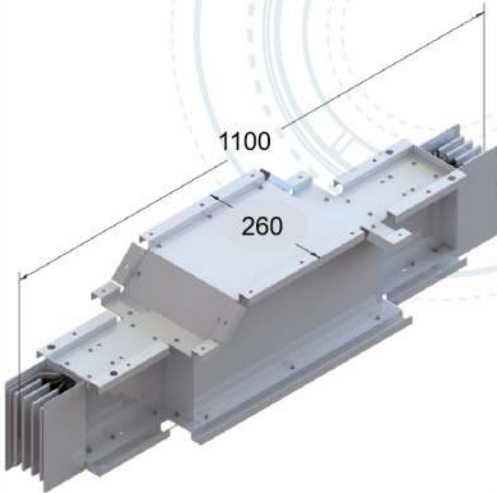

Edgewise Offset

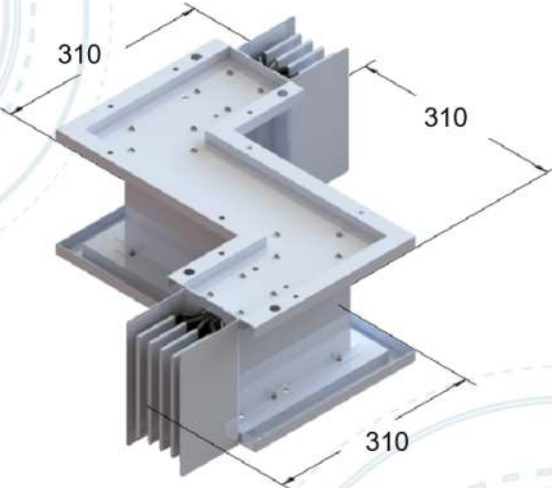

Reducer

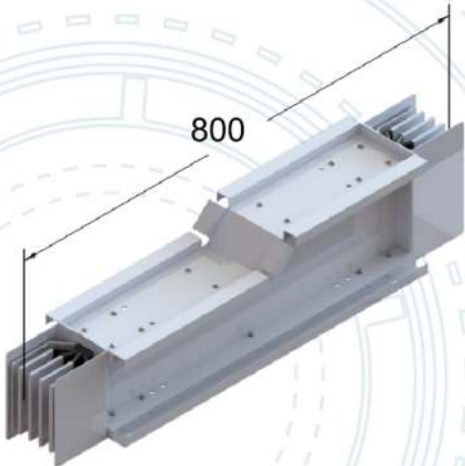

Expansion Unit

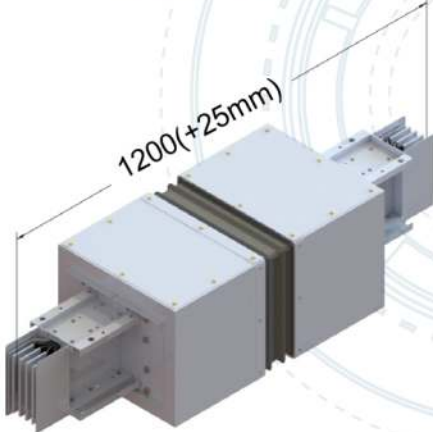

Noted: * Edgewise Elbow = Horizontal Elbow
 * Flatwise Elbow = Vertical Elbow
 * Refer to manufacturer for SPECIAL degree Elbow

MEGADUCT

Tap-Off Unit

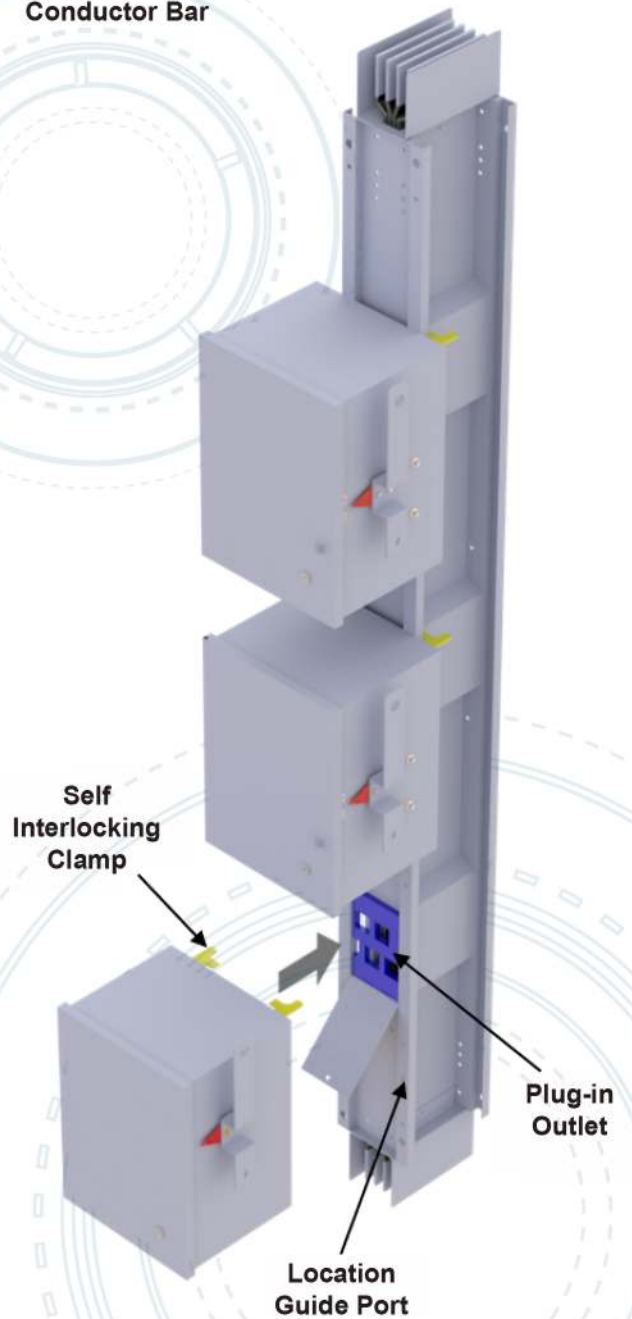
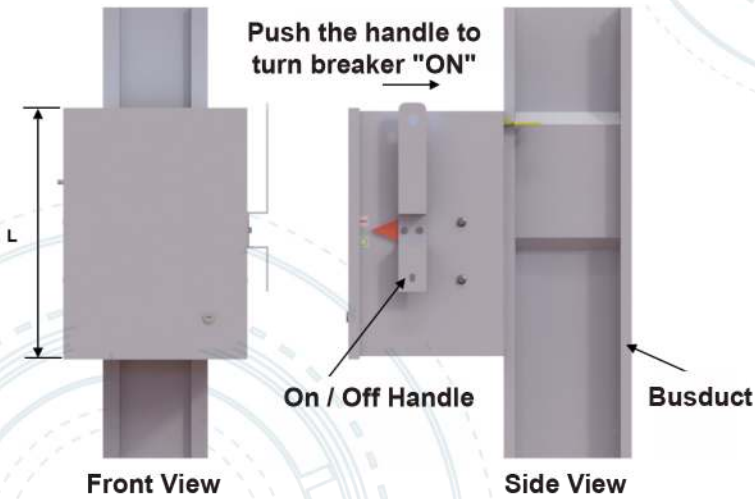
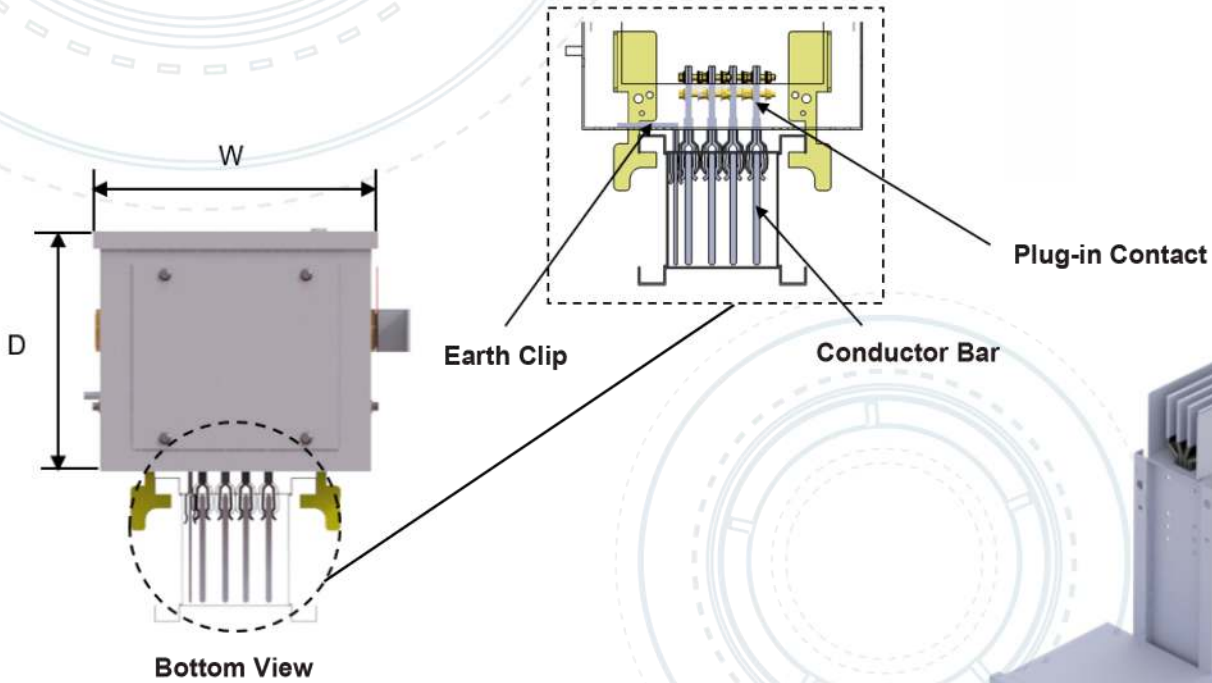

Ampere (A)	Box Size (mm)		
	D x W x L		
15A ~ 125A	220	250	350
150A ~ 400A	250	250	500
500A ~ 800A	300	350	850

- * Tap-Off Unit above 400A use double Plug-in outlet
- * Refer to manufacturer for Tap-Off above 800A
- * Box size may varies to MCCB Model, please refer to manufacturer for details
- * Quick and easy modifications or expansions with tap-off units (up to 800A) on energised¹⁾ busbars.

1) In accordance with EN 50110-1 (VDE 0105-1); please always observe national regulations/standards.

Horizontal Support(Clip)

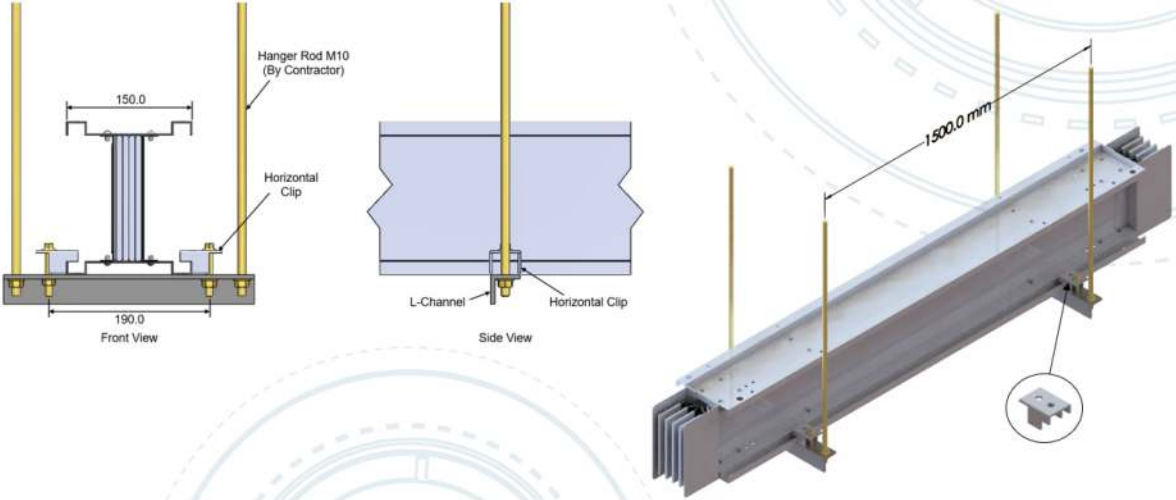

Vertical Fixed Support

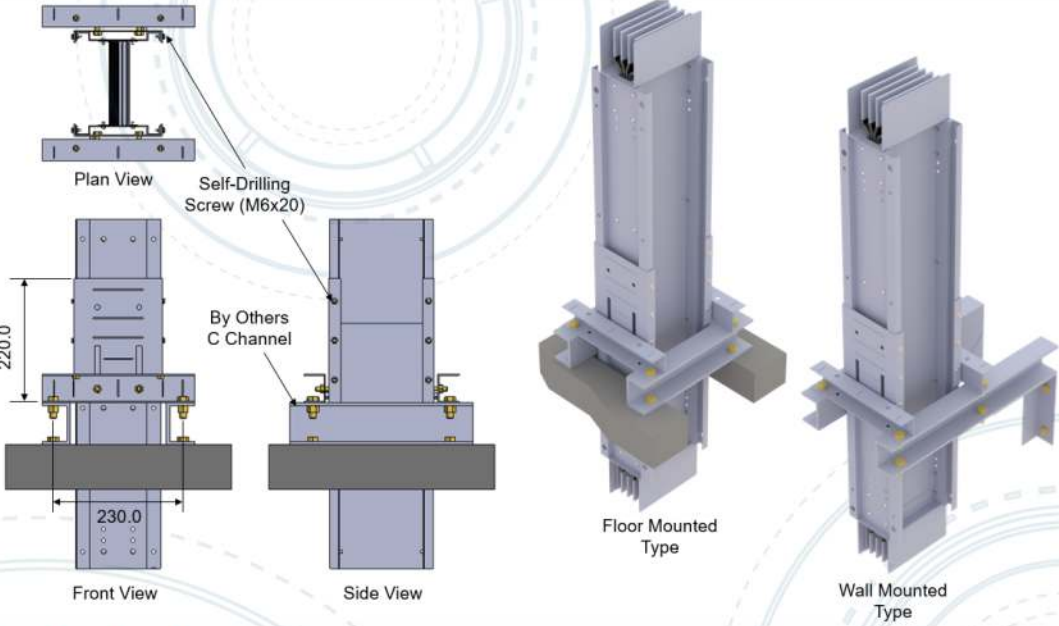

Vertical Spring Hanger

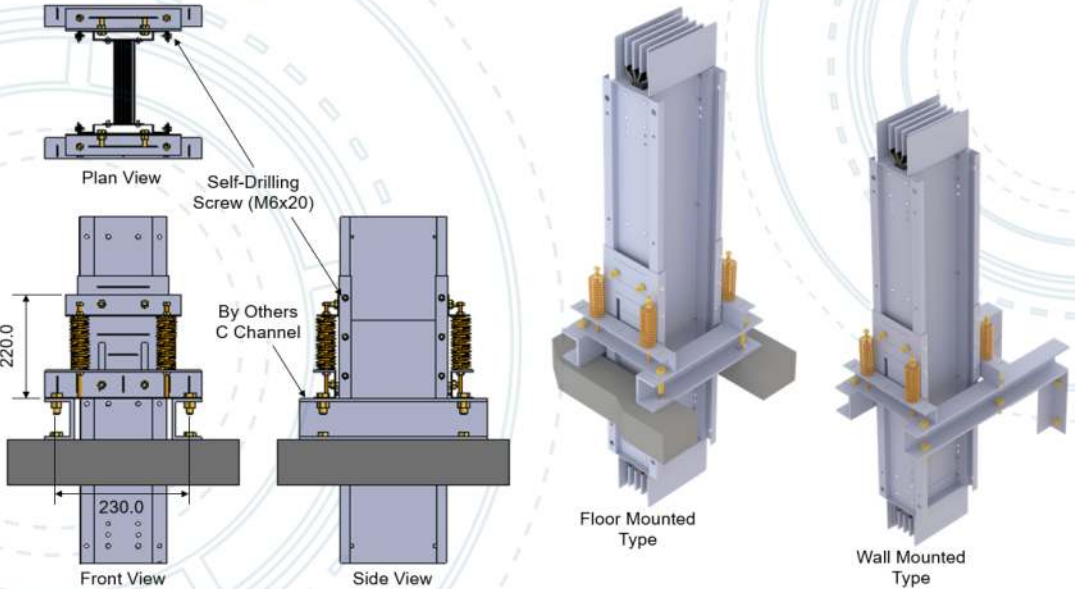

BUSDUCT LAYOUT DESIGN CONSIDERATION

Minimum Distance From Beam

(BUSDUCT UNDER BEAM WITHOUT JOINT POINT)

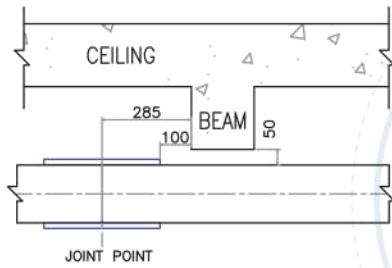
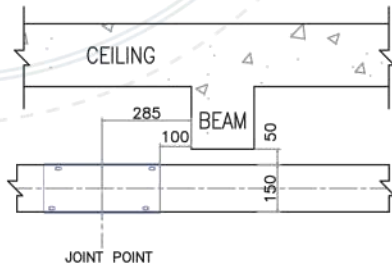

(BUSDUCT UNDER BEAM WITH JOINT POINT)

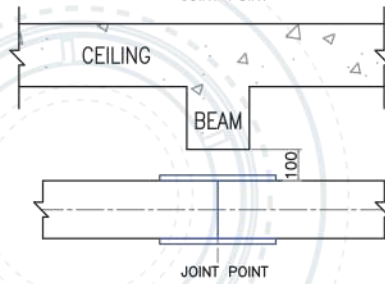
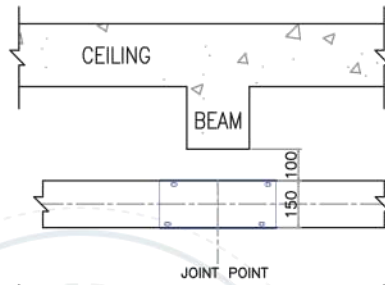

Minimum Distance From Wall

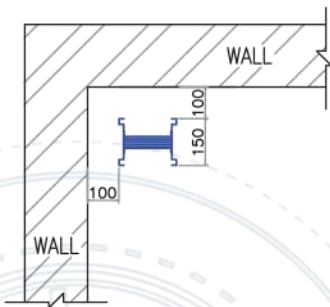

Minimum Distance From Wall And Ceiling

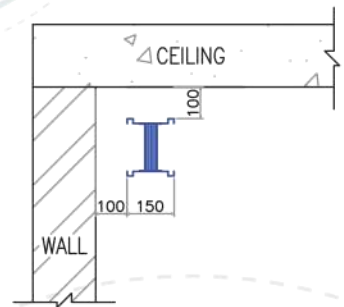
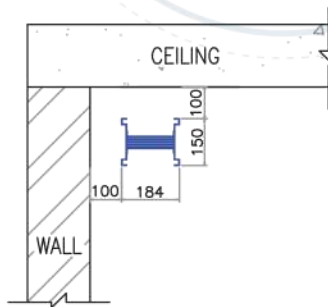

Busduct Jointing Point Through Wall Opening Installation (Joints Should Not Be Installed Inside Walls)

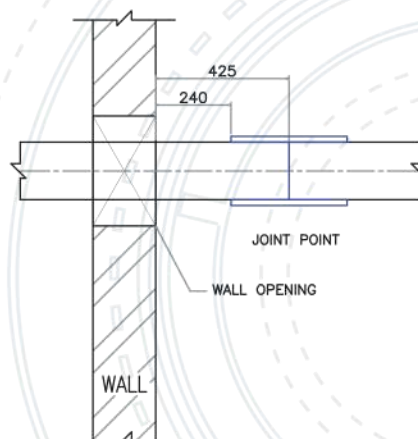
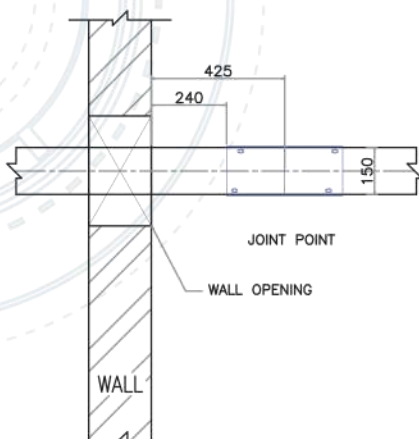

BUSDUCT LAYOUT DESIGN CONSIDERATION

Minimum Clearance Of Vertical Feeder Busduct Joints Side By Side

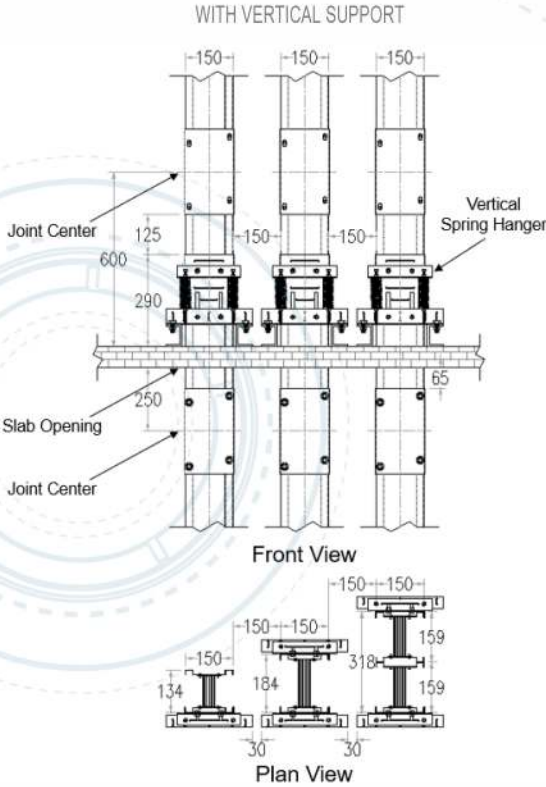

IN PARALLEL POSITION WITH VERTICAL SUPPORT

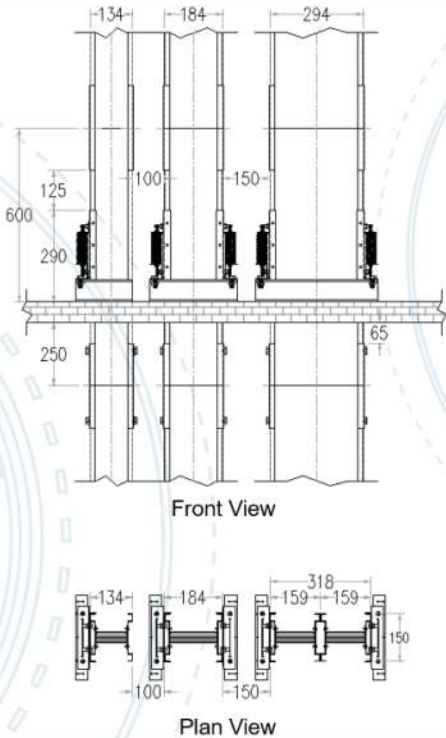

MEGADUCT

BUSDUCT LAYOUT DESIGN CONSIDERATION

Minimum Clearance Of Vertical Plug-In Busduct With Tap-Off Unit Installed

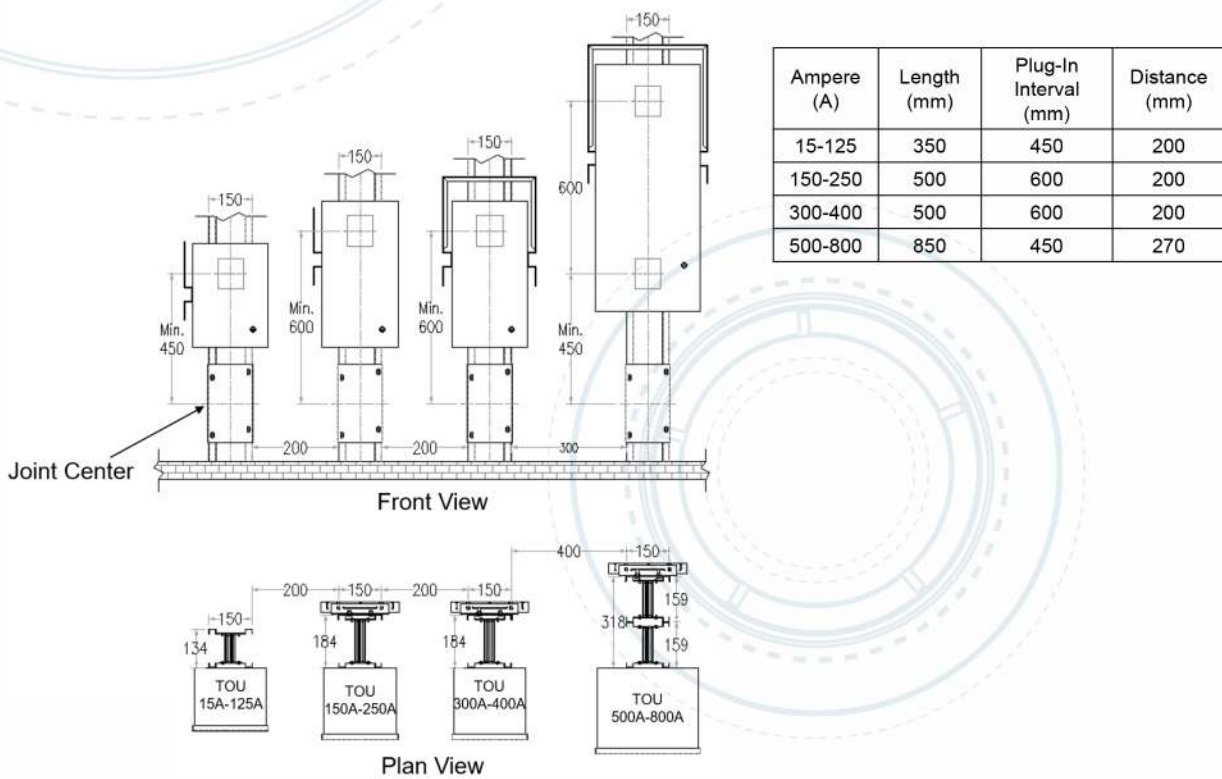

Minimum Clearance Of Plug-In Busducts With Tap-Off Unit Installed Flat In Parallel Position

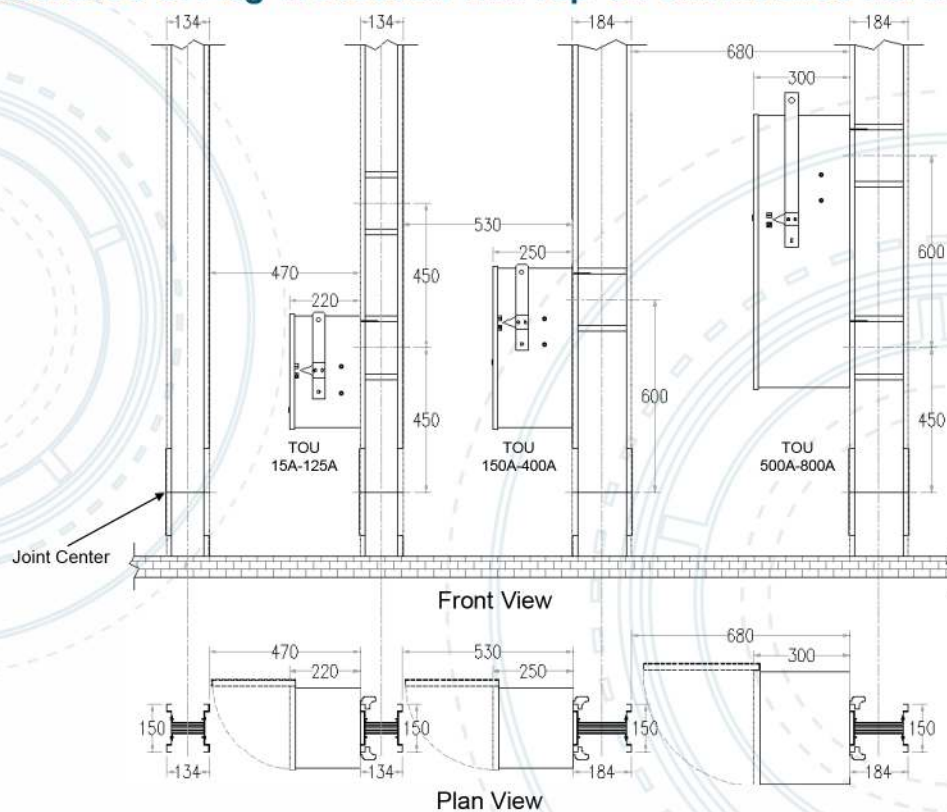

MEASUREMENT GUIDELINE

Feeder

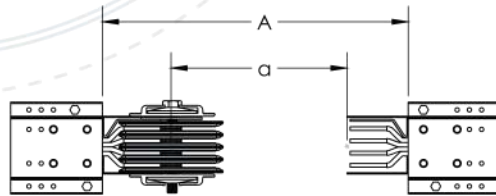

$$a = A - 115\text{mm} - 115\text{mm}$$

Example:
A=800mm

$$a = 800 - 115 - 115$$

$$a = 570\text{mm}$$

Flatwise Elbow

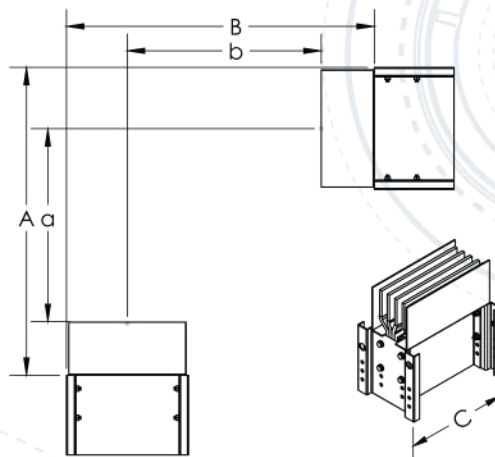

$$a = A - 115\text{mm} - C/2$$

$$b = B - 115\text{mm} - C/2$$

Example:

A=800mm, B=1000mm,
C=180mm

$$a = 800 - 115 - 180/2$$

$$a = 595\text{mm}$$

$$b = 1000 - 115 - 180/2$$

$$b = 795\text{mm}$$

Edgewise Elbow

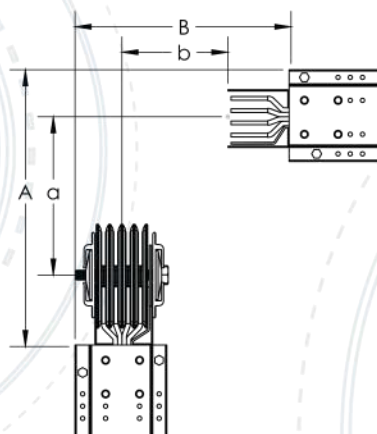

$$a = A - 115\text{mm} - 75\text{mm}$$

$$b = B - 115\text{mm} - 75\text{mm}$$

Example:

a=800mm, B=1000mm

$$a = 800 - 115 - 75$$

$$a = 610$$

$$b = 1000 - 115 - 75$$

$$b = 810$$

MEGADUCT

ILLUSTRATIONS OF MEGADUCT BUSDUCT TRUNKING SYSTEM

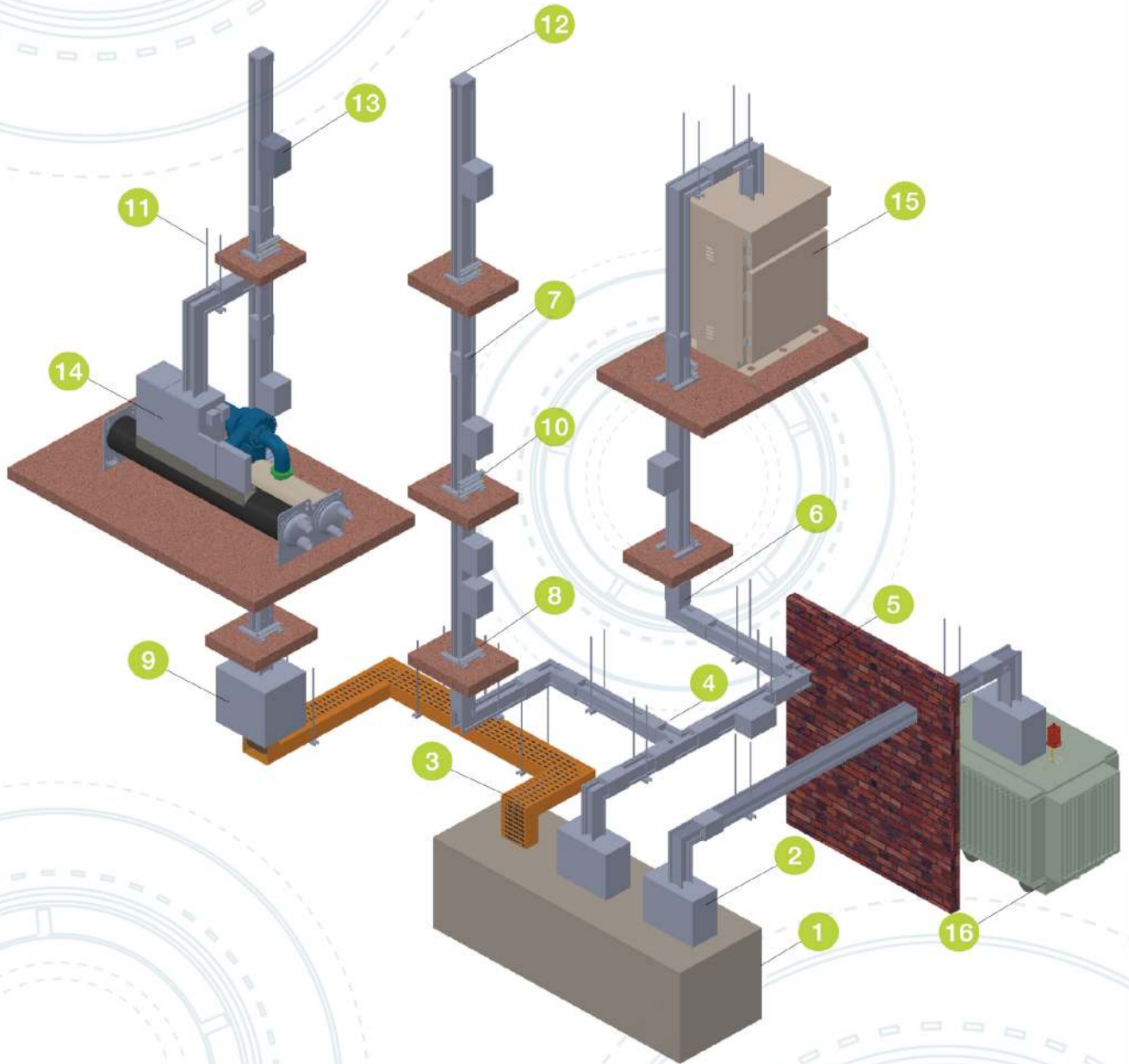

Power Transmission System

- | | | |
|-------------------------|-----------------------|---------------------|
| 1 Main switch board | 8 Fixed support | 15 Sub switch board |
| 2 Flange end connection | 9 End feed cable | 16 Transformer |
| 3 Cable tray | 10 Spring hanger | |
| 4 Tee section | 11 Horizontal support | |
| 5 Flatwise elbow | 12 End cover | |
| 6 Edgewise elbow | 13 Tap off unit | |
| 7 Joint | 14 Chiller | |

MEGADUCT

INSTALLATION

Step 01

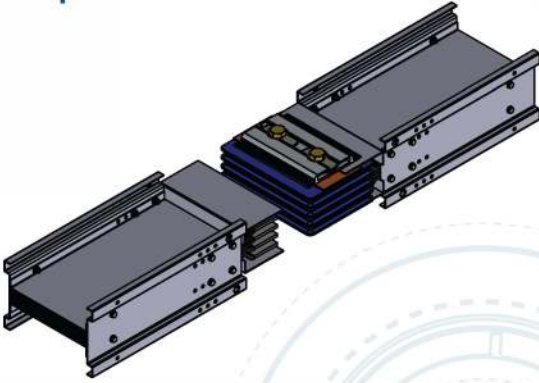

Step 02

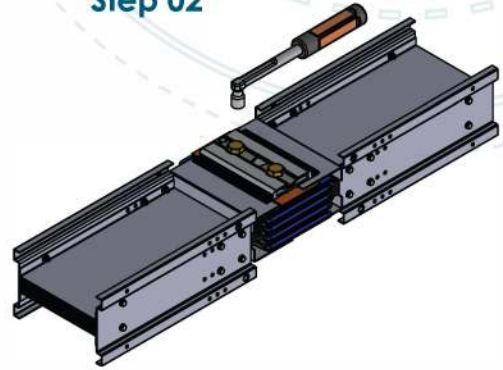

Step 03



(Side View)

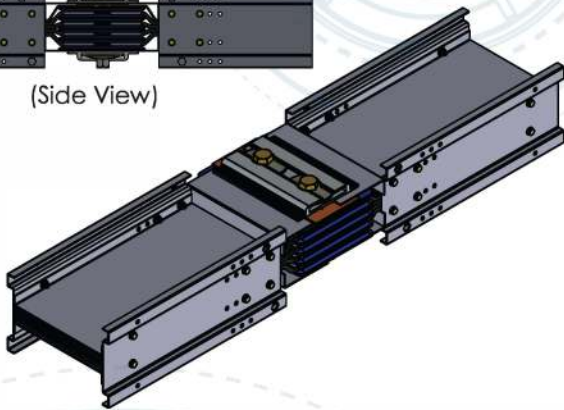

Step 04

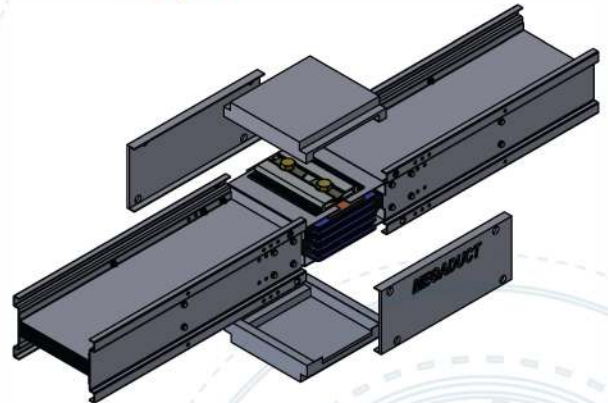

Step 05

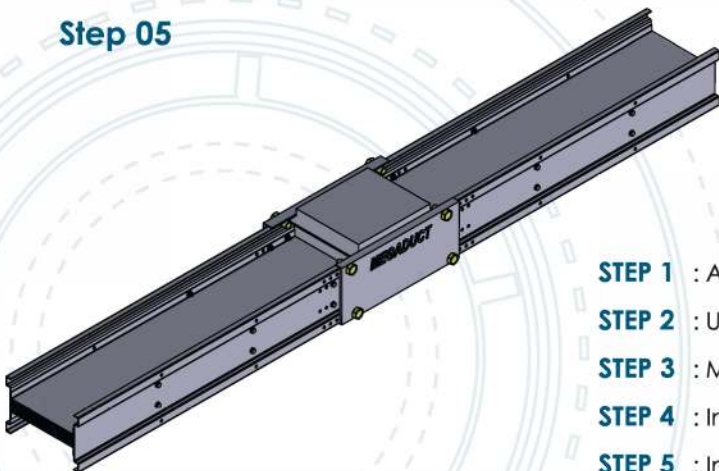

- STEP 1** : Align busduct with joint properly. Push busduct into joint.
- STEP 2** : Use torque wrench to tighten for about 70~75Nm.
- STEP 3** : Make sure busduct and joint are aligned properly.
- STEP 4** : Insert joint cover and joint side cover on the joint system.
- STEP 5** : Insert and fasten joint cover bolt.

MEGADUCT

QUALITY CONTROL



Temperature Rise



Dielectric Test



Pinhole Detector



Conductivity Test

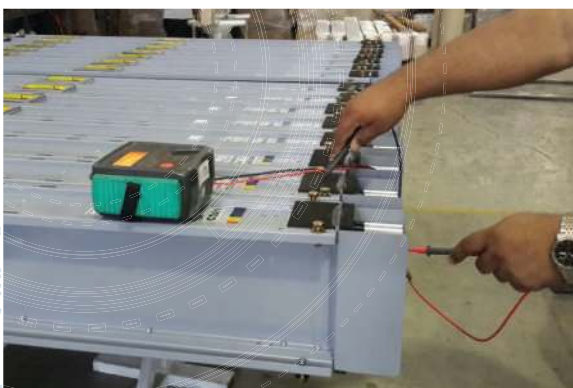

Megger Test



Epoxy Thickness Test

MEGADUCT

STANDARD & TESTING

Megaduct provides a good structure short circuit protection design which had been certified by ASTA, KEMA & UL



Megaduct Busduct is capable of carrying full rated current continuously in ambient condition of 95% related humidity and also ambient temperature in 50°C.



Busduct design verification according to IEC 61439.

- 10.2 Strength of material and parts.
- 10.3 Degree of protection of enclosure.
- 10.4 Clearance and creepage distances.
- 10.5 Protection against electric shock an integrity of protective circuits.
- 10.7 Internal electrical circuit and connections.
- 10.8 Terminals for external conductors.
- 10.9 Dielectric properties.
- 10.10 Verification of temperature-rise.
- 10.11 Short-circuit withstand strength.
- 10.12 Electromagnetic compatibility(EMC).
- 10.13 Mechanical operating.

PROJECT REFERENCES



MEGADUCT

PROJECT REFERENCES

Residences



AEQUA Sukhumvit 49,
Thailand



Marina Bay Central,
UAE



Forest City, Malaysia



Binh Khanh, Vietnam

Hotels



Shangri-La Hotel,
China



Langham Places,
Hong Kong



1 Borneo, Malaysia



Conrad Hotel,
Philippines

Commercial Complex / Business Premises



Oriental Plaza,
Vietnam



Equity Tower,
Indonesia



Saigon M&C Tower,
Vietnam



Telekom Tower,
Malaysia



Al Shoumoukh Tower,
Qatar

Airport / High Speed Rail Station

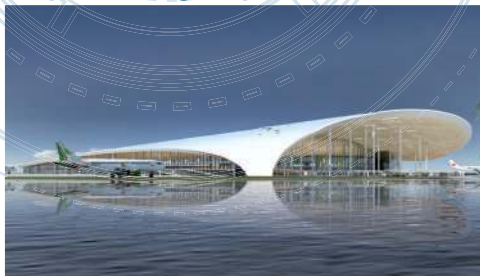

Male International Airport, Maldives



MRT, Singapore



HSR Zuoying Station, Taiwan

MEGADUCT

PROJECT REFERENCES

Hospitals

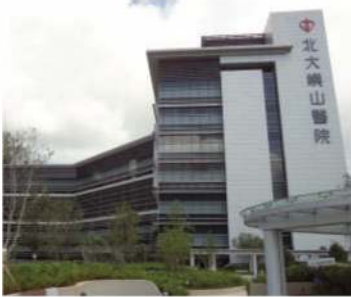

Lantau Hospital,
Hong Kong



Belfast City Hospital,
Northern Ireland



Bhumibol Adulyadej
Hospital, Thailand



Selayang Hospital,
Malaysia

Industries / Assembly Lines



Proton Factory, Shah Alam,
Malaysia



Perodua Assembly Plant,
Malaysia



Singpost Logistics Hub,
Singapore



Galtronics, Vietnam

Public Centres



Changi Prison,
Singapore



Garden By The Bay,
Singapore



Chiang Mai
Convention Centre,
Thailand



Customs
Headquarters
Building, Hong Kong



Shk Mohammed Bin
Rashid Library, UAE

Information Technology



Microsoft Office, India



PCCW, Hong Kong



Vista Hub, Philippines

CONTINUOUS BUSDUCT MONITORING SYSTEMS

Our Solutions

- We provide a temperature sensor that is not affected by electromagnetic noise.
- By quickly detecting overheating and pinpointing the location of a hotspot remotely, our thermal sensor ensures that any problem can be responded to immediately, before it leads to a costly and expensive plant shutdown. Our thermal sensor can be installed directly on a busbar and on the surface of a busbar or cover.

Benefits

Provide the temperature report quickly and accurately of any joints at any time.

- Monitor busbar and alert maintenance teams when aging and over-used equipment are on the verge of failure resulting in flash over.
- Improve human safety, reliability, quality of service, and ensure that equipment keeps running.
- Pinpoint exact location of the busbar when temperature spikes flag pending components failures.
- Accurate temperature monitoring under a strong electric field.
- Quick detection with abnormal location to prevent burnout.
- Condition based inspection work by temperature changes.

Temperature Trending



Vibration Trending

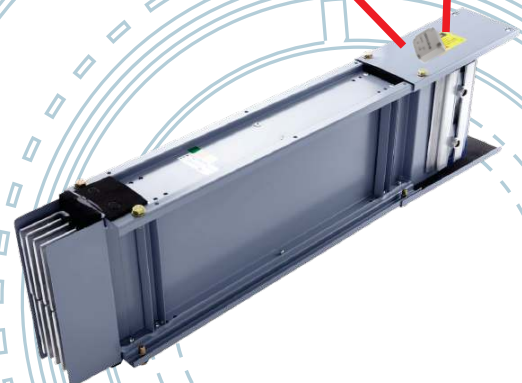
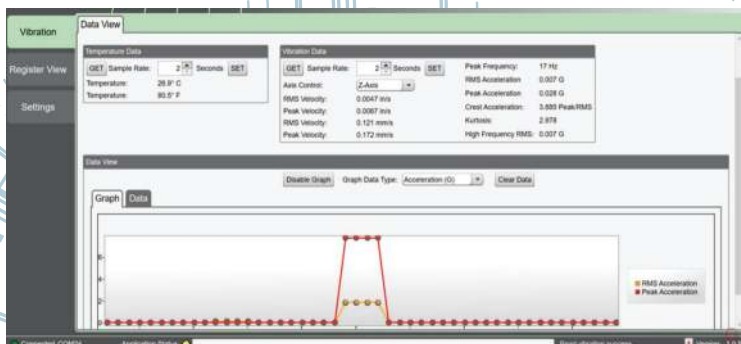

MEGADUCT

Marina 101 Dubai is the tallest residential building in the world which is 426.5m (1399ft) tall. There are total 16 runs of busways (3400m) in the building from 1200A to 4000A. The skyscraper will have 5-star hotel, residential apartment and restaurant in the hotel tower. The 101st floor of the skyscraper will feature a club lounge, restaurant and merchandise store.





Headoffice: LINKK BUSWAY SYSTEMS (M) SDN BHD
Lot 3226, Jalan Perindustrian Mahkota Utama,
Taman Perindustrian Mahkota,
43700 Beranang, Selangor Darul Ehsan.

Tel: +603 8727 6080

Fax: +603 8727 8081

Email: customerservice@linkk.com.my /
marketing@linkk.com.my

Web: www.linkk.com.my